

Assembly and operating instructions

Outdoor- charging station

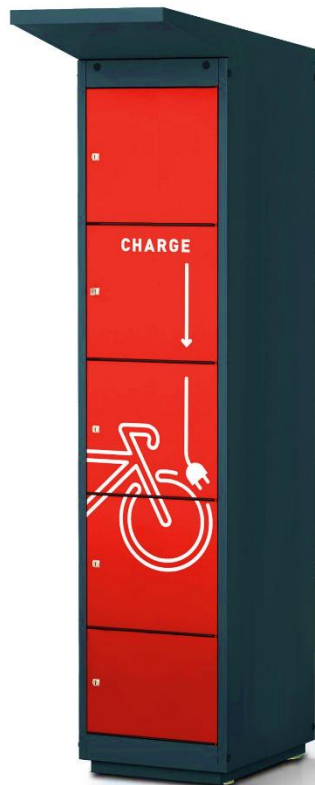

As a single column or as a combination with up to 16 compartments



Content:

| | | |
|-----------|---|----|
| 1. | Intended use and intended use..... | 3 |
| 2. | Essential components and equipment of the charging station..... | 4 |
| 3. | Technical data per column | 5 |
| 4. | Installation..... | 5 |
| 4.1. | Preparation: Concrete foundation & connection cable | 5 |
| 4.2. | Setting anchor points..... | 6 |
| 4.3. | Setting up Pillar 1 | 8 |
| 4.4. | Placing multiple columns side by side | 9 |
| 4.5. | Attach the base and side panels..... | 10 |
| 4.6. | Roof attachment | 11 |
| 4.7. | Power connection..... | 12 |
| 4.8. | Commissioning..... | 13 |
| 5. | Conformance..... | 13 |
| 6. | Cleaning | 13 |
| 7. | Regular inspection, maintenance..... | 14 |
| 8. | Disposal/ Recycling | 15 |
| 9. | Possible disruptions/ Troubleshooting..... | 15 |

1. Intended use and intended use



This accompanying documentation contains important information that must be read carefully before the plant is put into operation and kept for future reference.

The outdoor charging station is an electrical system. If the integrated sockets are damaged or defective, no electrical appliances may be connected to them. Any damaged sockets must be reported immediately to the owner/operator of the charging station. Repairs may only be carried out by the service provider, manufacturer, or an employee with the appropriate electrotechnical qualifications.

The charging station may only be connected to the electricity by a person with the appropriate electrical qualifications.

It is strictly prohibited to interfere with the electrical connection of the charging station!

The charging station is a steel cabinet with four user compartments and one service compartment as standard. Any deviation in the compartment distribution does not affect the content of this manual.

The charging station is designed to store and power electrical appliances, particularly e-bike chargers or batteries. Each user compartment is equipped with two 230 V / 16 A sockets, with a maximum power consumption of 460 W, allowing users to connect their chargers. Please note, the chargers are not included with the charging station.

The sockets are protected by a residual current circuit breaker with a residual response current of 30 mA. Each user compartment features lockable doors. Inside the service compartment, there is a small electrical panel, but this compartment is not freely accessible.

The charging station is an electrical system intended for protected outdoor spaces, with an ambient temperature range of -20°C to +35°C. It is weather-resistant for use in Central European latitudes. To ensure durability and enhance user-friendliness, the station should not be directly exposed to precipitation, moisture, or extreme temperatures. A sheltered, shaded location is recommended. If a canopy is planned, it must be at least 70 cm higher than the station to facilitate installation and easy access to the roof structure.

2. Essential components and equipment of the charging station

1) Front view, open doors:

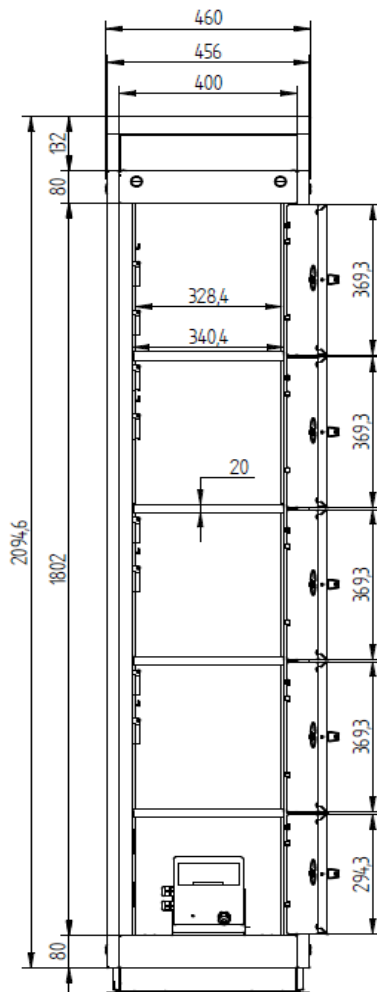

2) Side view with roof structure, open doors:

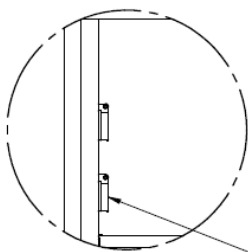
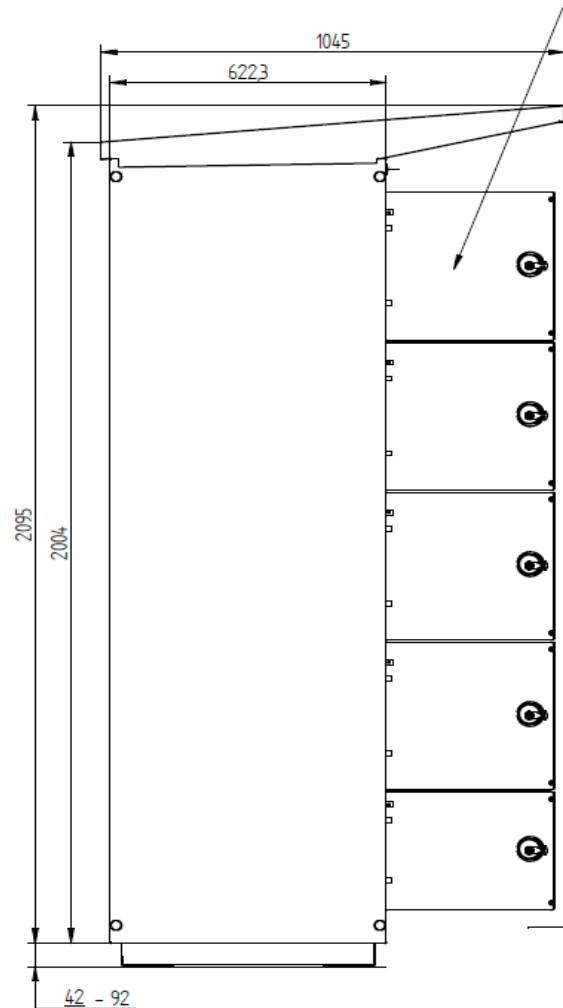

Detail upper compartment: User-friendly socket position further down

3. Technical data per column

| | |
|---|---|
| Number of electrical outlets | 4 x 2 Sockets |
| Height | 2095 + 42 bis 92 mm height-adjustable base |
| Width | 460 mm |
| Depth | 1045 mm inkl. Roof structure |
| Weight | 108 kg |
| Max. power consumption per user compartment | 460 W |
| Rated current | 16 A |
| Nominal voltage | 230 V AC |
| Protection | IP 44/20 |
| Ventilation | Passive through ventilation slots in the body |

4. Installation



- *The outdoor charging station must be placed on a stable and solid concrete foundation, securely fixed to prevent tipping, shifting, or other movements.*
- *The connection cable should be selected based on the distance from the power source and the on-site conditions.*
- *The assembly must be carried out by at least two qualified individuals.*

Required mounting material per column:

- 4 pieces of bolt anchors M10 with 4 pieces of washers (available from LOCKEEL[®]),
- Stepladder
- suitable tool for drilling Ø10mm and screwing size 19-24,
- Allen key size 8,
- Angle grinder if necessary

Instruction videos: <https://rotstahl.de/tutorials/>

4.1. Preparation: Concrete foundation & connection cable

Before installing the charging cabinet, prepare the concrete foundation as shown in Photo 3 below. The charging cabinet must be installed upright on a flat **concrete foundation with the minimum dimensions** outlined in Table 1, and with a recommended thickness of 500 mm (adjustable based on local conditions). The concrete foundation must be at least 50 mm higher than the surrounding terrain.

For the first column to be installed, a **cable conduit for the power supply connection** must be routed through the center of the foundation. If multiple columns are placed next to each other, the cable can be extended from the first column to the next. The connection cable **for each column** must be

at least three-core, with a **minimum cross-section of 2.5 mm²**. The cable size should be selected based on the distance from the power source; the recommended cable type is NYY-J 3x2.5 or an equivalent.

Table 1: Foundation dimensions

| Number of columns next to each other | Width of the entire system (columns incl. side panel) | Minimal Foundation | | |
|--------------------------------------|---|------------------------|------------------|----------|
| | | Total foundation width | Foundation Depth | Strength |
| 1 Column | Column 1: B 460 mm | B 460 mm | 620 mm | 500 mm |
| 2 Columns | Column 1: B 430 mm, Column 2: B 430 mm | B 860 mm | | |
| 3 Columns | Column 1: B 430 mm, Column 2: B 400 mm, Column 3: B 430 mm | B 1.260 mm | | |
| 4 Columns | Column 1: B 430 mm, Column 2: B 400 mm, Column 2: B 400 mm, Column 4: B 430 mm | B 1.660 mm | | |

4.2. Setting anchor points

Once the concrete foundation has been prepared according to the instructions (*for a single column, refer to photo 3*), the anchoring points for the first column can be marked. The drilling template is included in the delivery and corresponds to the dimensions of a column with side panels, approximately W 460 x D 620 mm (*see 5*). If necessary, adjust the cut-out for the cable duct. Place the template on the foundation, ensuring the short side of the drilling diagram is flush with the leading edge of the concrete foundation and aligns with the future end of the charging station. Then, mark the positions for the four drill holes (*see photo 4*).

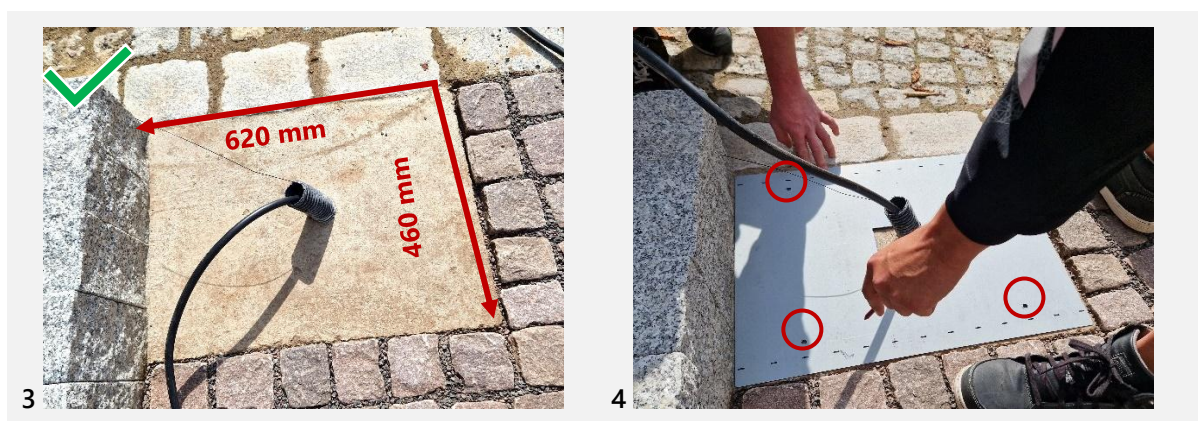

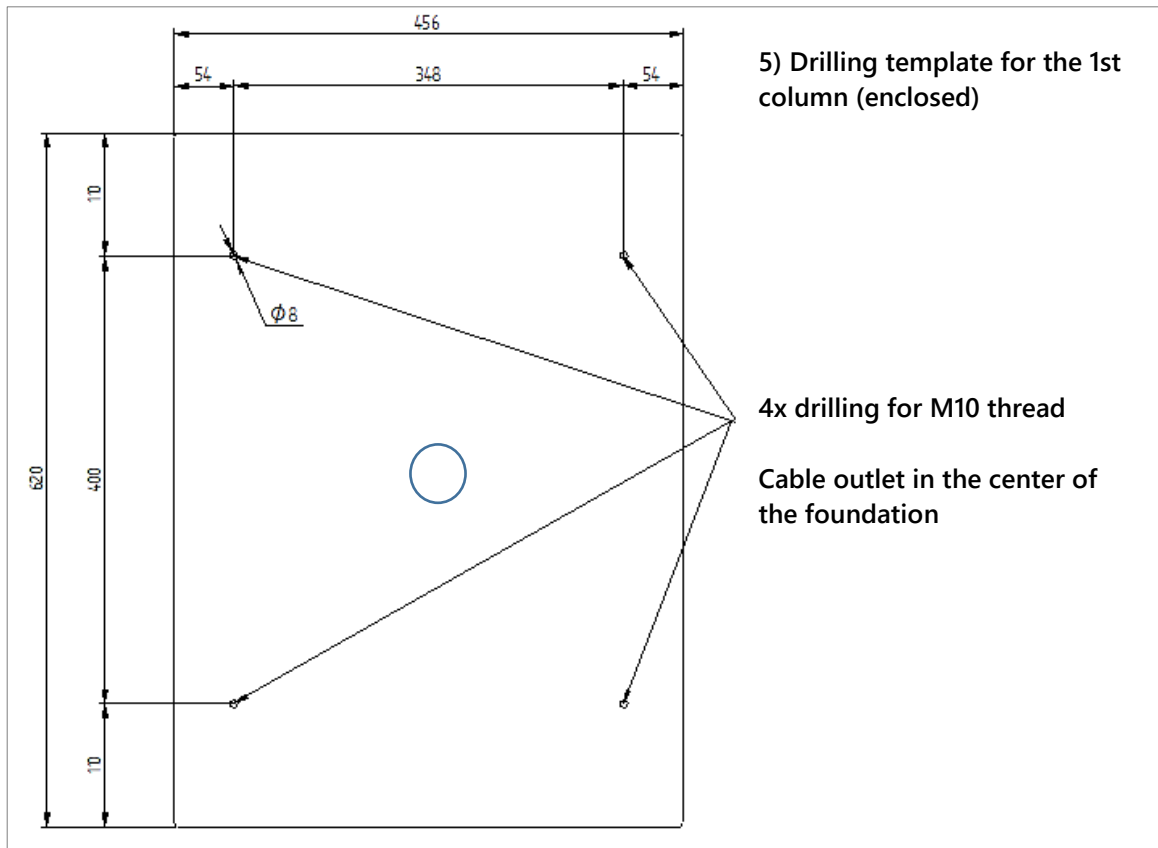

Next, drill the 4 holes into the concrete foundation.

Then, fix 4 pcs. M10 anchor bolts into the concrete foundation.

The threaded rods should protrude no more than 30 mm from the concrete foundation to ensure proper installation of the side bases. (s. photo 6).



4.3. Setting up Pillar 1

Once the anchoring points and cable are prepared, the charging station can be installed on the concrete foundation. To begin, unscrew the side panels (if available) as shown in *photo 7*. Then, prepare the enclosed base panels, typically located in the lower service compartment. Finally, place the cabinet onto the prepared threads (*see photo 8*).



7

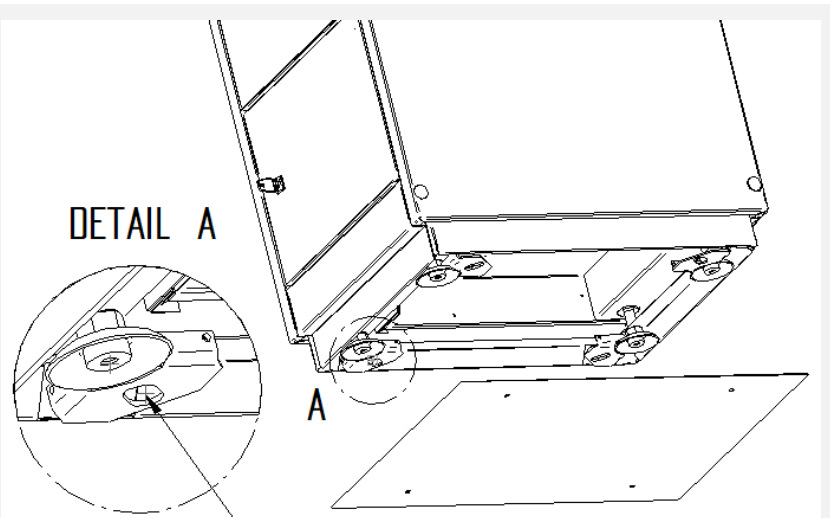

8

Place the station onto the 4 prepared bolts.

Lead the power cable through the side cable grommet on the left into the service compartment (*see photo 9*).



9

For leveling, there are 4 holes in the service compartment, through which the leveling feet can be adjusted with an Allen key (see photo **10**).



After aligning the cabinet, equip the threaded rods with washers (enclosed) and nuts and tighten them sufficiently (see photo **11**).



4.4. Placing multiple columns side by side

When mounting multiple columns, at least 1 column must be anchored with 4 holes, starting from one outside of the foundation. All other columns must be fixed with at least 2 holes each. The use of the drilling template is only recommended for pillar 1. From pillar 2 onwards, alignments are made with the previous column to compensate for any unevenness or measurement inaccuracies. All the pillars must be connected to each other.

Procedure:

- For Pillar 1, follow all steps outlined in sections 4.2 and 4.3 and secure it using the 4 anchoring bolts. It is recommended to start on one of the outer sides to ensure proper cable feed-through.
- Position Pillar 2 flush next to Pillar 1 and mark the two external drill holes. Secure it with 2 anchoring bolts.
- Connect Pillar 1 and Pillar 2 using the provided connection screws.
- Place Pillar 3, and so on, next to the previous pillars, and repeat the same procedure.
- Refer to section 4.5 for covering instructions and to section 4.6 for roof attachment guidelines.
- Instructional video available at: <https://rot-stahl.de/tutorials/>

Scheme:

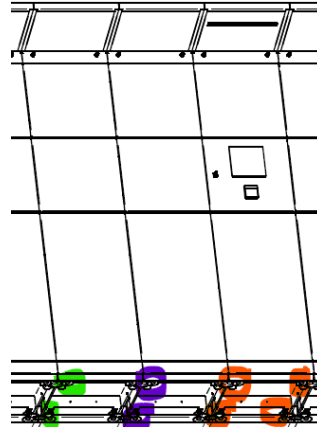

4.5. Attach the base and side panels

Place the side plinth panels on the outside, pin them together with the plastic rivets on the front panel (see photo 12).



Screw on the side panels on the outside (see photo 13). Insert the cover caps onto all perforations on the panels and in the service compartment (see photo 14).

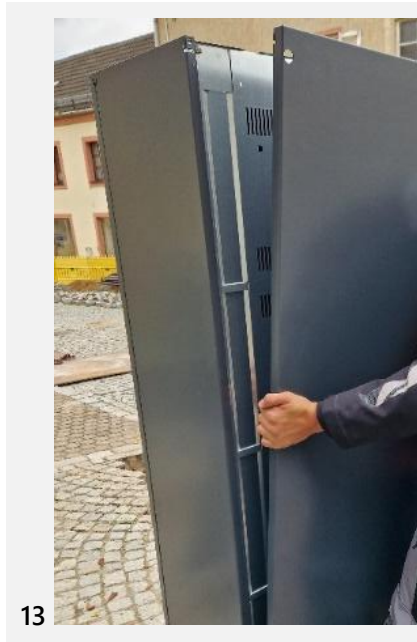

4.6. Roof attachment

If the station is covered (e.g., with a bicycle shelter or similar structure), ensure that at least 70 cm of height is available to facilitate proper installation and easy opening of the roof structure.

Lift the roof attachment onto the station in pairs, positioning the rear hinges inside (see photo 15). For easier installation, extend the two roof supports (see photo 16).



Fix the hinges with the supplied connecting screws (see photo 16+17). Then connect all yellow-green ground cables to the side panels (and to the roof if LED lighting) (see photo 18).



Close the roof, lock both locks and lock the roof (see photo **19**). Keep keys safe ("service key roof").



When installing several columns with roofs next to each other, a rainwater drainage channel is used between the roofs, see instruction video: <https://lockeel.com/tutorials/>

4.7. Power connection



- Only persons with the appropriate electrical engineering qualifications may carry out the electricity connection.
- Before working on the charging station's power connection, make sure the connection cable is disconnected from the power source.

The connection cable is attached to the electrical control panel in the service compartment at the bottom. For easier handling, it is recommended to unscrew the bracket of the power box. The brown and blue conductors should each be connected to the upper terminals of the combined circuit breaker (RCD), while the green and yellow conductor should be connected to the green bridge.

After connecting the cable, you can switch on the combined circuit breaker to supply power to the sockets in the individual user compartments. The power to the connection cable is then switched on at the local distributor.



4.8. Commissioning



Before commissioning, it is necessary to carry out an initial inspection of the electrical system. After the overhaul, the charging station can be operated.

The opening and locking of the user compartments depends on the selected lock type. Devices with a maximum total power consumption of 460 W can be connected to a socket.

5. Conformance

In accordance with the manufacturer's specifications, the charging station complies with the following directives: 2014/30/EU of 26 February 2014 – Electromagnetic Compatibility Directive, 2014/35/EU of 26 February 2014 – Low Voltage Directive, EN 50110-1:2013 - Operation of electrical installations, HD 60364-4-41:2017 - Protective measures – Protection against electric shock. The manufacturer's nameplate (ALFA 3, s.r.o., Husova 247, 538 54 Luže, CZ) can be found in the service compartment (see photo 20).

6. Cleaning



- *Disconnect the charging station from the mains without exception before each cleaning!*
- *The electrical components of the charging station must never come into contact with moisture or moisture! This also applies to moisture or wetness that can be caused by foam or other cleaning agents as well as cleaning utensils!*
- *Never touch live components with damp or wet hands!*
- *If the electrical sockets are damaged, cleaning is prohibited.*

Never use harsh, corrosive cleaning agents, as the paint could become dull or even peel off. Electrical or electronic components could be damaged. Plastics or stickers could become porous or brittle.

Light soiling

We generally recommend wiping the charging station with a dry, soft, and clean cloth. Light dirt can also be removed with a slightly damp cloth without the use of cleaning agents. If you use a damp cloth, be sure to wipe the cleaned areas dry immediately afterward. To loosen slightly hardened dirt, place a slightly damp cloth over it and then wipe it away.

Heavy soiling

If you wish to clean the charging station with biological or chemical cleaning agents, we recommend testing the agent first on a concealed area of the cabinet. Please apply the cleaning agent sparingly and only to the area being cleaned. Afterward, wipe the affected area with a cloth dampened with clear water, and then dry it. Electrical or electronic parts must never be sprayed. We do not accept any guarantee or liability for any resulting property damage or personal injury caused by the use of sprayed cleaning agents.

Disinfection

Please use slightly damp disinfectant wipes to disinfect the cabinet and its components. If you do spray disinfectant, you must immediately wipe the treated areas dry. Electrical or electronic parts must never be sprayed! We do not accept any guarantee or liability for property damage or personal injury resulting from the use of sprayed disinfectants.

7. Regular inspection, maintenance



The electrical and mechanical components of the charging station must be regularly checked and maintained by suitable and trained specialists!

To ensure safe operation, the following steps must be carried out regularly (at least 1x annually). You can obtain any necessary spare parts from LOCKEEL®:

- *Inspection of supply lines*
Perform a visual inspection of the supply lines at least once per year. This includes checking the screw connections and the transfer pieces.
- *Control signage*
Verify that all signage is complete and up-to-date. Replace any missing or damaged signage as needed.
- *Inspection and maintenance of closures*
Each lock must be functionally tested. For locks with batteries, check the charge level and replace the batteries if necessary.
- *Inspection of moving components*
Inspect all components of the cabinets visually, checking screw and plug connections, and tighten them if needed.

- *Documentation of the work*
All maintenance and service work must be documented clearly and comprehensively. Guarantee

We offer a guarantee and warranty on the charging station in accordance with the current terms and conditions, which can be viewed at www.lockeel.com.

8. Disposal/ Recycling



Before dismantling, make sure that the charging station is disconnected from the mains!



At the end of the charging station's life, the operator/owner is obligated to dispose of it in an environmentally responsible manner or to drop it off at a collection point in accordance with local regulations. The product is made from fully recyclable materials. Please separate the electrical and electronic components, such as those made of plastic and rubber, from the sheet steel housing before disposal.

9. Possible disruptions/ Troubleshooting

What to do in the event of a defective charging station:



- *If you notice damage to sockets, cables, or housings, a designated person must disconnect the charging cabinet from the power supply and ensure that the faults are fixed.*
- *Any repair may only be carried out by qualified specialist personnel or the manufacturer. Modifying electrical components is prohibited.*
- *The charging cabinet must be taken out of service until the defects have been rectified.*

In the event of any malfunction, the operator/owner must be contacted.

If one of the sockets in the user compartments is overloaded, the combined protection device RCD located on the electrical control panel will trip. In this case, an authorized person disconnects all connected electrical appliances from the double sockets and attempts to reset the combined protection device RCD.

If the circuit breaker does not trip, it indicates that too many electrical appliances were connected to the double sockets. Fewer electrical appliances need to be connected.

If the protection device RCD trips again even without connected electrical appliances, there is a fault in the electrical installation. In this case, the service/manufacturer must be contacted or the repair must be carried out by an employee with electrotechnical qualifications.

If troubleshooting does not succeed or an unknown fault occurs, disconnect the station from the power supply and inform customer service. (Tel. +352 27 404 930, Email: info@lockeel.com).